

Acequia Lift Station 30-inch Force Main Project

CO-00633

Joshua Garcia, P.E.

Senior Project Engineer, Construction Management

Roxanne Lockhart

Contract Administrator

Tracy M. Burns

SMWB Specialist

Ian Toohey, P.E.

Project Manager, Garver USA

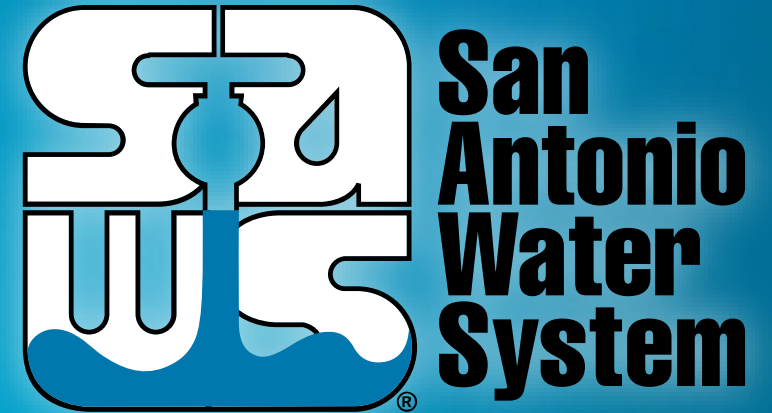

Non- Mandatory WebEx Pre-Bid Meeting

March 24, 2023

MAKING SAN ANTONIO
WATERFUL



WebEx Reminders

- Stay muted during the entire presentation.
- Please sign-in using the chat feature with the following information:
 - Name, Company, Email Address
- Ask questions at any time during the presentation utilizing the Chat. Questions will be addressed at the end of the presentation.
 - Ensure to direct your questions to the entire group by selecting everyone from the drop down.
 - All formal responses to questions will be provided via an Addendum.
- Audio only attendees may follow along on the presentation posted to the SAWS solicitation website.

Oral Statements

Oral statements or discussion during the pre-bid meeting today will not be binding, nor will it change or affect the terms or conditions within the Plans and Specifications of this Project. Changes, if any, will be addressed in writing only via an Addendum.

Agenda

- General Information
- Non-Mandatory Site Visit
- SMWB Requirements
- Contract Solicitation Website
- Vendor Registration & Notification (VRN)
- Solicitation Schedule
- Contract Requirements
- Bid Packet Preparation
- Bid Opening Procedures
- Questions
- Restriction on Communication
- Contact Information
- Project Overview
- Project Details

General Information

- This is a non-mandatory pre-bid meeting
- This presentation has been posted and the attendance sheet will be posted at the end of this meeting, to the SAWS website
- Construction services being procured through low bid under Chapter 2269 of the Texas Government Code
- A Geotechnical Report is available on the SAWS website and accessible once an electronic disclaimer form is signed
- Key Project Information:
 - Estimated Budget: \$2,459,027.00
 - Calendar Duration: 300 days

Non-Mandatory Site Visit

- Reference Site Visit Procedures
- March 24, 2023 at 2pm
- Address to site visit is 8600 Mission Pkwy, San Antonio, Texas 78223 15 minutes prior to site visit time
- Site visit duration – 1 hour (excluding drive time)
- No Q&A during site visit
- Purpose is to allow Contractors to visit project areas in person:
 - Existing SAWS Acequia Lift Station
 - SAWS Acequia Lift Station Access Road
 - Existing Force Main Easement along mission Parkway ROW
 - Other areas upon request

Aspirational SMWB Goal

Industry	Aspirational SMWB Goal
Construction	20%

The aspirational SMWB goal is 20% of your total bid price

Minimum Qualifications for SMWB recognition:

- South Central Texas Regional Certification Agency
 - Must be SBE-Certified (including MBEs and WBEs)
 - Texas Historically Underutilized Business “HUB” Program
- Local Office or Local Equipment Yard
 - Bexar, Comal, Guadalupe, Hays, Travis, and Williamson counties.

Good Faith Effort Plan (GFEP) FAQs

- **Q: Is the 20% SMWB goal mandatory?**

A: No, but we ask prime contractors to do their best with good faith outreach efforts. If the goal is not met, proof of outreach efforts is required with the submittal.

- **Q: What if I am having trouble finding SMWB subcontractors?**

A: The SCTRCA has a search portal at www.sctrca.sctrca.org. Please make sure to include SAWS-specific parameters in your search. Contact Marisol Robles at Marisol.Robles@saws.org if assistance is needed.

- **Q: What if my business is SMWB-certified? Do I need to find SMWB subs?**

A: If your firm is SMWB-certified, you will most likely meet the goal. However, the GFEP is a required document, and a good faith outreach effort is still necessary.

- **Q: Do I need to include all my subcontractors in the GFEP or just those that qualify towards the SMWB goal?**

A: All subcontractors need to be included in the GFEP, even those that may not count towards the SMWB goal.

- **Q: What if I have questions about the GFEP?**

A: Please contact the SMWB Program Manager at 210-233-3420, or at Marisol.Robles@saws.org. GFEP questions can be asked at any time before the submittal is due.

Post Award: Subcontractor Payment & Utilization Reporting (S.P.U.R.) System

1. Subcontractor & Supplier Payment Tracking
2. Subcontractor and Supplier Additions or Substitutions
3. Must be Current and Accurate before Retainage is released

<https://saws.smwbe.com>



The screenshot displays the homepage of the San Antonio Water System's Subcontractor Payment & Utilization Reporting System. The header features the San Antonio Water System logo on the left, the text "OUR MAIN SITE" in the center, and a "CONTACT SUPPORT" button on the right. The main content area has a blue background with a photograph of industrial water treatment equipment. The title "Subcontractor Payment & Utilization Reporting System" is prominently displayed in white, with a "Log In" button below it. Below the main content, there are three columns of links: "System Training" (with a "Training" button), "About the System" (with an "Information for Vendors" button), and "Account Access" (with "Account Lookup" and "Forgot Password" buttons). A footer at the bottom states: "The Subcontractor Payment & Utilization Reporting System is powered by B2Gnow Software © Copyright 2018."

Contract Solicitations Website

- To locate the Contract Solicitations, go to the SAWS website at www.saws.org, click on the drop-down menu for Resources and select Business Center

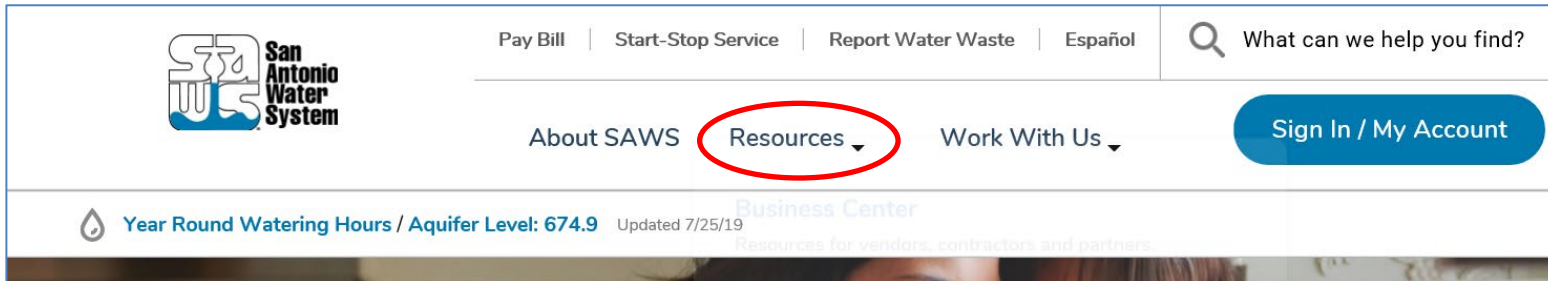

- At the left-hand menu choose Contract Solicitations

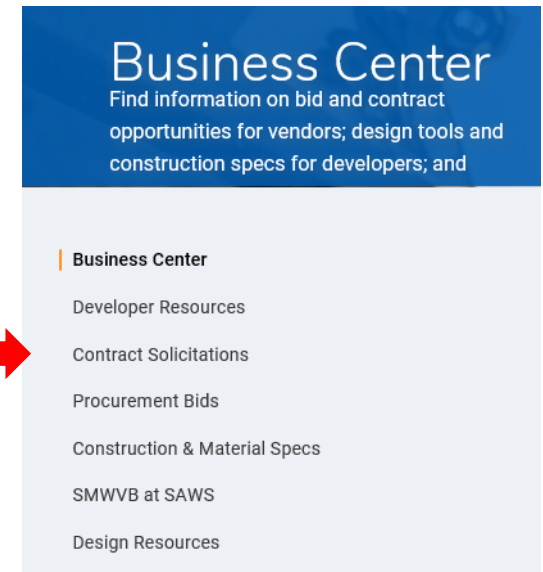

Contract Solicitations Website

- Choose the specific project
- The following buttons are located under the advertisement:
 - *Notify Me - Subscribe
 - Plan Holder’s List – View List
 - Downloads
 - Specifications
 - Plans
 - Addendums
 - Engineering Reports



Non-Mandatory Pre-Bid Meeting
10:00 AM, Monday Oct. 31, 2022
WebEx

Notify Me
Receive updates sent straight to your inbox.

Plan Holders List
View plan holders list.

Downloads

[CO-00609 Specifications](#)
Oct. 20, 2022
Note: You must be logged in to access this document.

[CO-00609 Plans](#)
Oct. 20, 2022
Note: You must be logged in to access this document.

[CO-00609 Geotech Report](#)
Oct 20, 2022
Note: You will be prompted to login to access this document.

Questions? Please contact Roxanne Lockhart at 210-233-3095 | [Receive Email Updates](#) | [Registration Agreement](#)

* To receive updates on specific projects, registered vendors must ‘Subscribe’ to the project by selecting the project, and clicking ‘Subscribe’ under the Notify Me box

Vendor Registration & Notification (VRN)

- Please register through SAWS Vendor Registration Program on the SAWS website at [Business Center - San Antonio Water System \(saws.org\)](https://www.saws.org) to ensure access to the latest information.

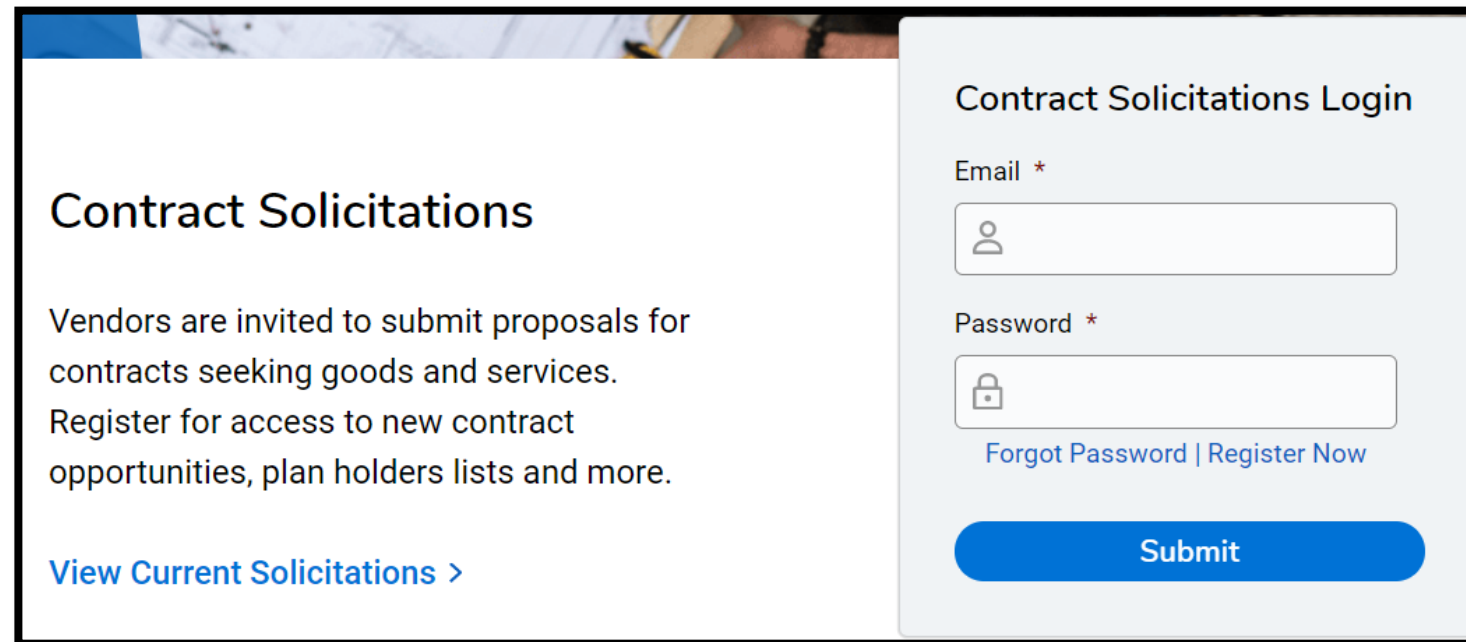

Contract Solicitations

Vendors are invited to submit proposals for contracts seeking goods and services. Register for access to new contract opportunities, plan holders lists and more.

[View Current Solicitations >](#)

Contract Solicitations Login

Email *

Password *

[Forgot Password | Register Now](#)

Submit

Solicitation Schedule

MILESTONE	DATE / TIME
Non-Mandatory Pre-Bid Meeting	March 24, 2023, at 10:30AM (CDT)
Non-Mandatory Site Visit	March 24, 2023, at 2:00PM (CDT)
Questions Due	April 3, 2023, at 4:00PM (CDT)
Answers Posted	April 10, 2023, at 4:00PM (CDT)
FTP Request Deadline	April 18, 2023, by 2:00PM (CDT)
Bids Due	April 19, 2023, by 2:00PM (CDT)
Lowest Responsible Bidder Notified	April/May 2023
Board Award	June 2023

Contract Requirements

Prevailing Wage Rate and Labor Standards – Section 2.10 of the General Conditions

- Wage decisions are included within the specifications
- Contractors shall utilize LCP Tracker
- Certified payroll to be submitted on weekly basis beginning on the start date of the Notice to Proceed, including weeks in which work is not performed
- Contractors are responsible for sub-contractor payroll
- Late payrolls delay contractor payments, as well as release of retainage at the end of the project
- Payroll records are subject to review
- Site visits are random and unannounced
- Interviews will be conducted and will be private & confidential
- All apprenticeship programs will need to be approved by Department of Labor prior to starting

Contract Requirements

- Insurance requirements are found in Section 5.7 of the GCs Supplemental Conditions
 - **Installation Floater insurance in lieu of Builder's Risk**
- Contractor's insurance must be compliant with all other contracts
- SAWS will request insurance certificate prior to Board award to ensure insurance compliance and to assist in expediting execution of the contract
- Contractor must ensure insurance is compliant for the duration of the contract

Contract Requirements

Supplemental Conditions (Continued)

- Contractor shall perform the work with its own organization on at least 40% of the total original contract price which should be indicated on the Good Faith Effort Plan.

Type/s of Certification: SBE: _____ MBE: _____ VBE: _____ WBE: _____

Prime Contractor's Percentage of Participation: (Ex: 100% is the total value of the contract.) _____%

Describe your firm's participation to be performed on this Project: _____

- Liquidated damages will be assessed at \$1400.00 per day

Bid Packet Preparation

- Only limited items are required with the initial bid packet
 - List of Bid Items
 - Bid Packet Checklist
 - Signed Bid Proposal Signature Page with
 - Acknowledgement of all Addenda
 - Executive Order
 - Signed Proposal Certification
 - Bid Bond
 - Good Faith Effort Plan

Bid Packet Preparation

Apparent Low Bidder

- Notified by SAWS within 24 hours of Bid Opening to provide the following within one (1) business day
 - Conflict of Interest Questionnaire - Form CIQ (Rev. 1/1/2021)
 - Proof of Insurability
 - Company Information Packet
 - Statement regarding ability to complete the project
 - W-9
 - Statement of Bidders Experience
 - Detailed Baseline Schedule using NTP date of April 6, 2023 (see Supplemental Condition)
- *And, if bid was submitted electronically without a Bid Bond:
 - Cashier's Check or Certified Check

Bid Packet Preparation

- Utilize the Bid Packet Checklist within the specifications
- Double check all mathematical calculations and verify all extensions
- Ensure Mobilization & Prep ROW Line Item does not exceed the percentage allowed (**lines 1-35**)
- Addendums are acknowledged on the Bid Proposals
 - Check the SAWWS website regularly for addendum postings
 - It is possible to have multiple addendums

Bid Opening Procedures

- Bids will be submitted using SAWS' electronic bid opening procedures
- SAWS encourages and prefers the submission of electronic bids using its secure FTP site.
 - Bidders should submit a request via email to obtain access to the site no later than 24 hours before the bid opening.
- Or, Bidders may drop off a hard copy bid. Only required items.
 - Drop box is located at 2800 US Hwy 281 N, Customer Service Tower
 - Enter the first set of glass double doors
 - Insert into the black drop box on the wall on the left-hand side
- Late bids will not be accepted and will not be opened.
- Bid Opening will be handled via WebEx only; reference the Invitation to Bidder's for the link

Questions

- All questions should be sent in writing to the corresponding Contract Administrator by email Roxanne.Lockhart@saws.org or fax, 210-233-4438.
- Please identify the project by its associated solicitation number.
(CO-00633)

Restriction on Communication

Please be advised that Bidders are prohibited from communicating with any other SAWS staff, the Consultant, or City of San Antonio officials regarding this IFB up until the contract is awarded as outlined in the Instructions to Bidders

Acequia LS & FM – Site Conditions

- Located within the San Antonio Missions Historical Park (World Heritage Site)
- Environmentally Sensitive Area (ESA)
 - Adjacent to San Antonio River & San Juan Acequia
 - Floodplain permit
 - Tree Permit
- Property owned by SARA
 - Will need to coordinate access
- Managed by NPS

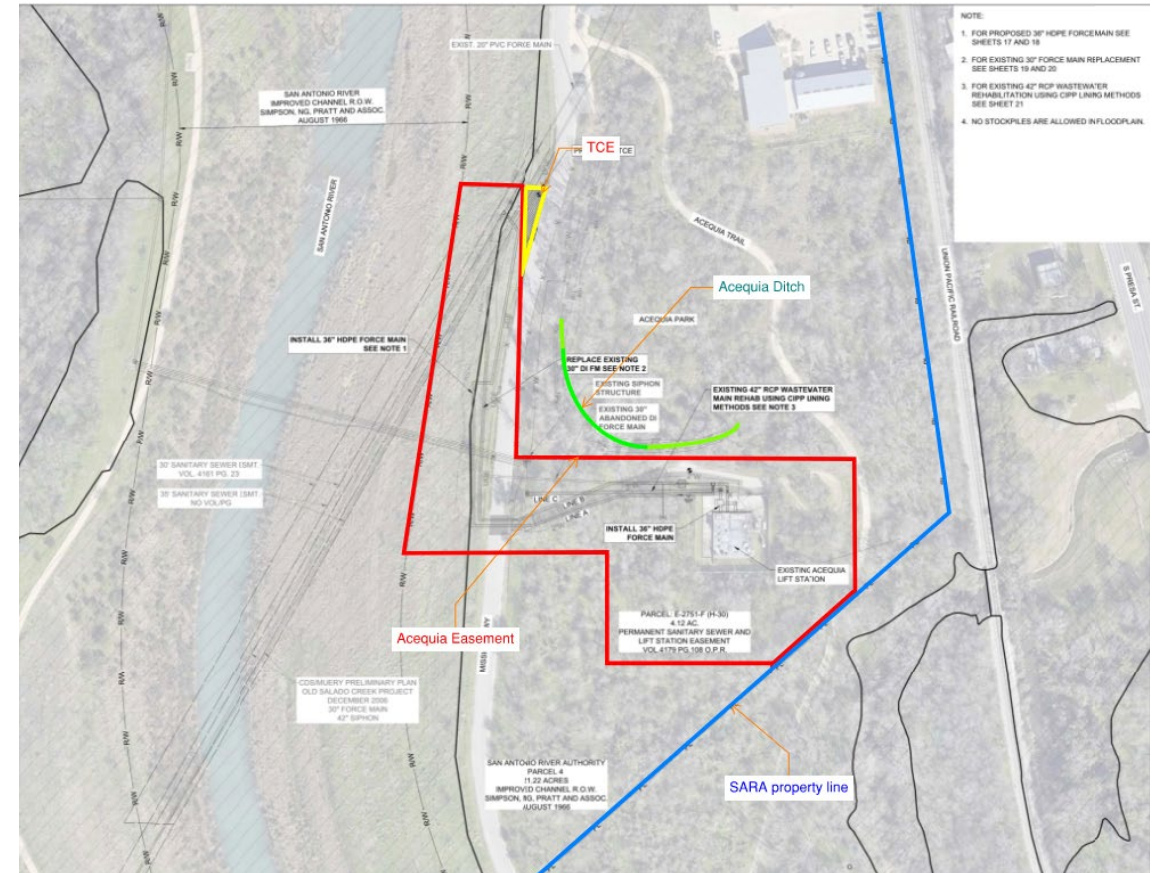

Acequia LS & FM – Existing Conditions

- Improvements to existing:
 - Lift station
 - 42” wastewater main
 - Existing plug valves
 - 30” DI force main
 - Substantial pipe degradation



Acequia LS & FM – Improvements

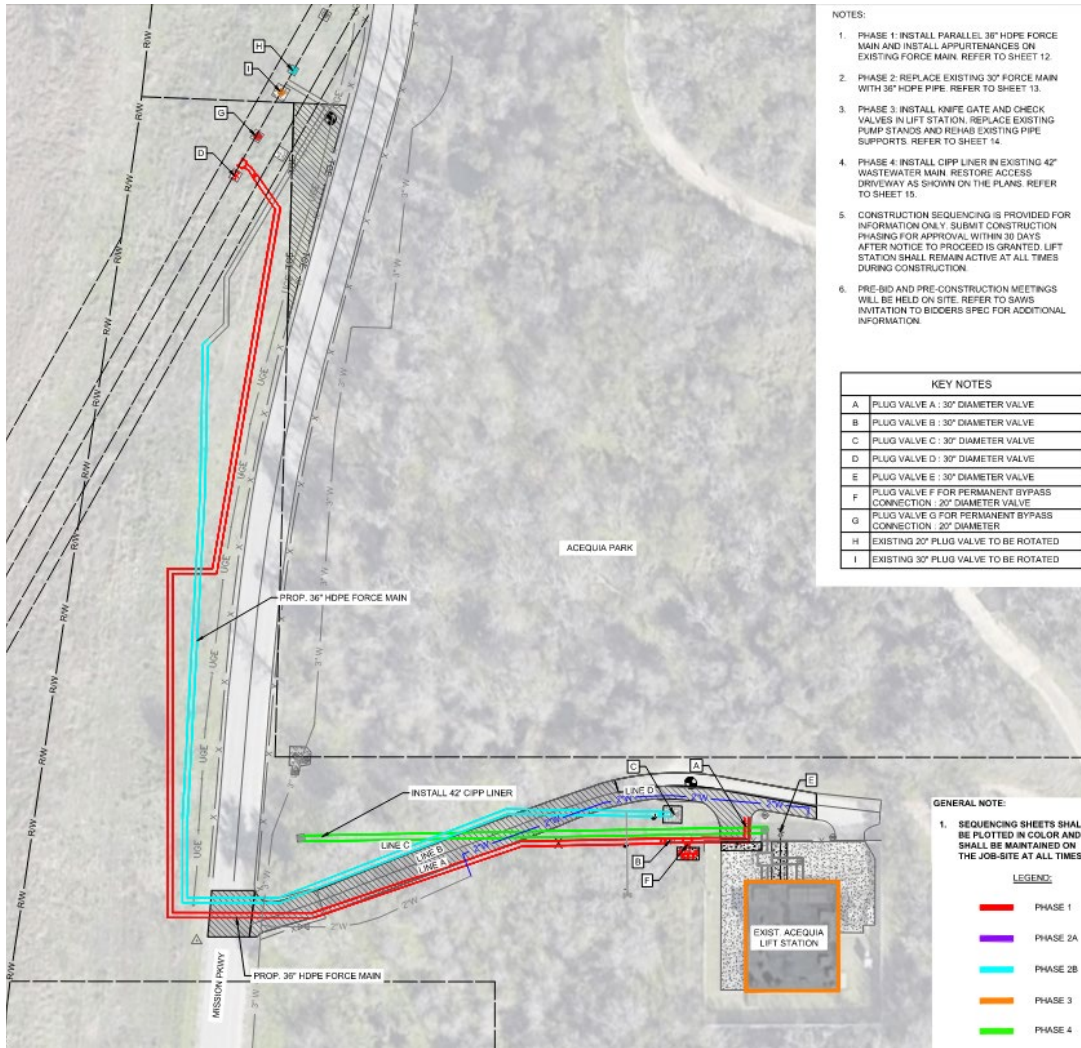

- Force Main Improvements
 - Install parallel 36" HDPE force main & appurtenances
 - Replace existing 30" Force Main
 - Install permanent bypass structure
- Lift Station Improvements
 - Knife gate
 - Check valves
 - Pump stands and supports.
- Gravity Main Improvements
 - CIPP existing 42" RCP wastewater main.

Special Considerations

- Valve procurement
 - Plug Valve
 - Knife gate
 - Check valves
- SARA hydromulch requirements
 - Special Provision Technical Spec

KEY NOTES	
A	PLUG VALVE A : 30" DIAMETER VALVE
B	PLUG VALVE B : 30" DIAMETER VALVE
C	PLUG VALVE C : 30" DIAMETER VALVE
D	PLUG VALVE D : 30" DIAMETER VALVE
E	PLUG VALVE E : 30" DIAMETER VALVE
F	PLUG VALVE F FOR PERMANENT BYPASS CONNECTION : 20" DIAMETER VALVE
G	PLUG VALVE G FOR PERMANENT BYPASS CONNECTION : 20" DIAMETER
H	EXISTING 20" PLUG VALVE TO BE ROTATED
I	EXISTING 30" PLUG VALVE TO BE ROTATED

Remediation Seed Mix

Variety	Species	%
Alamo	Switchgrass	5
Native	Little bluestem	5
South Texas	Sideoats grama	10
Lavaca Germplasm	Canada wildrye	10
Welder germplasm	Shortspike windmill grass	5
South Texas	Green sprangletop	10
n/a	Silver bluestem	10
Hidalgo Germplasm	4 flower trichloris	10
Dilley Germplasm	Slender grama	5
Catarina blend	Bristlegrass	5
n/a	Texas Cupgrass	5
n/a	Partridge pea	3
Balli Prostrate	Illinois bundleflower	3
n/a	Indian Blanket	3
Zapata Rio Grande	Clammyweed	2
Aztec	Maximilian sunflower	3
n/a	lemon mint	3
n/a	Standing cypress	3

Special Considerations

- Wall Penetration

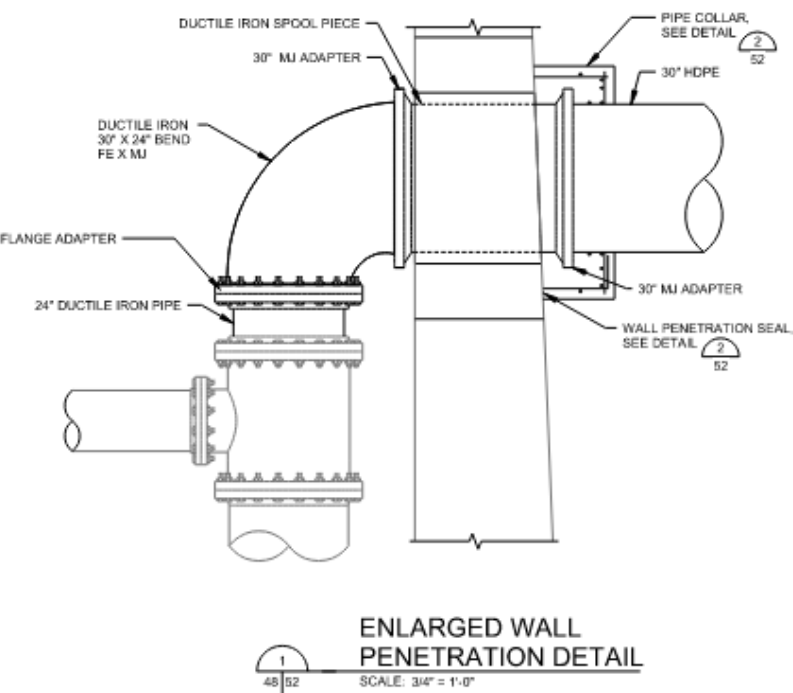

- Acequia

- Archeological monitoring
- No spoils stored in floodplain
- Contractor to provide SWPPP

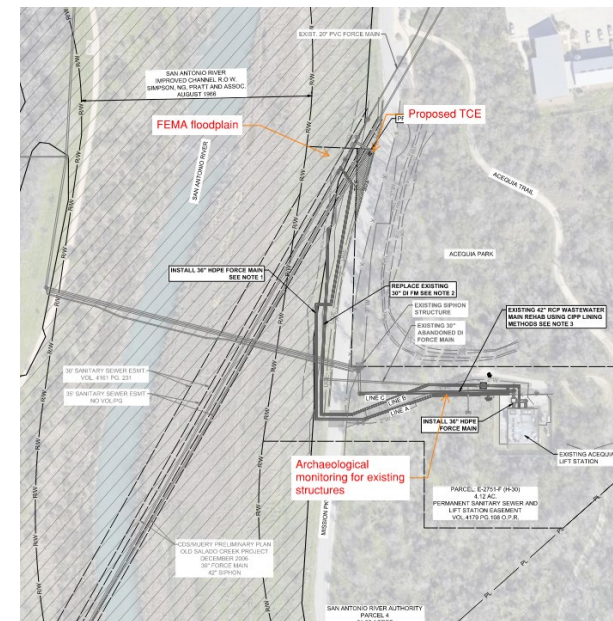

Contact Information

<u>Contact Name</u>	<u>Title</u>	<u>Telephone Number</u>	<u>Email address</u>
Roxanne Lockhart	Contract Administrator	210-233-3095	Roxanne.Lockhart@saws.org
Marisol V. Robles	SMWB Program Manager	210-233-3420	Marisol.Robles@saws.org

QUESTIONS?

Reminder: Oral statements or discussion during the pre-bid meeting today will not be binding, nor will it change or affect the terms or conditions within the Plans and Specifications of this Project. Changes, if any, will be addressed in writing only via an Addendum.

Acequia Lift Station 30-inch Force Main Project

CO-00633

Joshua Garcia, P.E.

Senior Project Engineer, Construction Management

Roxanne Lockhart

Contract Administrator

Tracy M. Burns

SMWB Specialist

Ian Toohey, P.E.

Project Manager, Garver USA

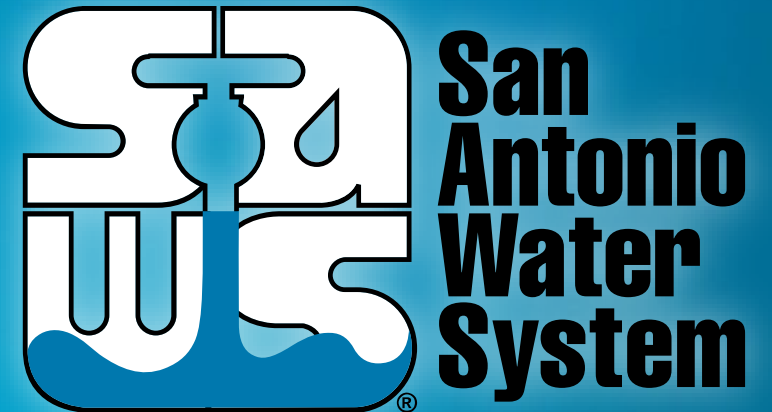

Non- Mandatory WebEx Pre-Bid Meeting

March 24, 2023

MAKING SAN ANTONIO
WATERFUL

